



CT01 Roller Conveyor Alignment 24V



Smart & flexible

The modular platform of Inther Conveyor Equipment (ICE) is unique due to the short installation and commissioning time. All components (both mechanical and electrical) come pre-installed in our modules, including cabling and the correct E-plan codes.

The smart and flexible modules are available in various widths and are suitable for transporting all common goods in intralogistics.



Alignment 24V

The CT01 Roller Conveyor Alignment 24V aligns materials to the left or to the right. There are many benefits to this alignment feature including, getting an ideal scanning position or correctly applying a label to the material.

- › Fully modular
- › Integrated and labeled cabling
- › Fast installation time

Technical specifications

General information

Max. carrying weight	35 kg/zone
Transport speed	Min. 0,05 / max. 2,2 m/sec.
Ambient temperature	+5°C to +40°C

Drive transport

Voltage	24V DC
Drive	1 motor roller per zone
Drive coupling	Round belts
Control	Conveylinx AI
Power consumption per engine	2A (Peak, ECO+ mode)

Electrical connection

Connection voltage	90-265V AC / 1-phase
Connectivity	0,9A (240V AC)
Connection plug	7/8" Female, 3 pins
Work switch	Included
Sensor	Retro-reflective, installed and wired

Dimensions

LW effective width	420/620 mm
ML module length	max. 3000 mm
TW module width	LW + 96 mm
P roller pitch	75/100/125 mm
SF side guide	80 mm

Side profile

SP Profile height	126 mm
-------------------	--------

Rollers

Material	Steel 1,5 mm, galvanized
Diameter	50 mm
Performance	Round head

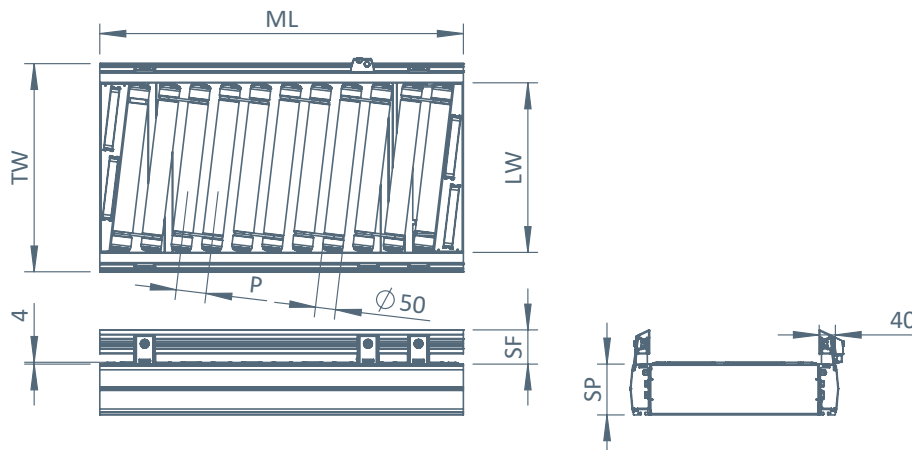

Inther

Conveyor Equipment

 **The Netherlands (HQ)**
De Amfoor 15
5807 GW Venray
+31 478 50 25 75

 **USA**
+1 866 292 8266

 **China**
+86 512 65030958

 **Germany**
+49 5224 98 58 78

 **Belgium**
+32 3 336 07 35

info@inthergroup.com
www.inthergroup.com



IN THER
improving intralogistics